

Easy-FORK Vision Systems

Front mounted camera & Line Laser

Well protected, best visibility, centered vision camera

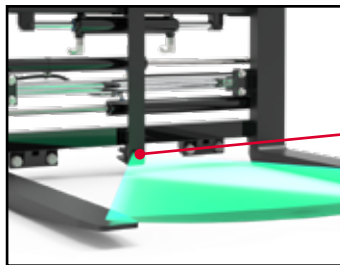
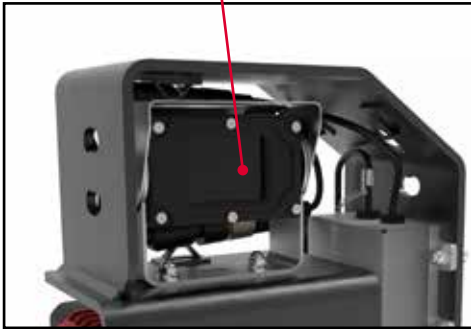

Line laser configuration

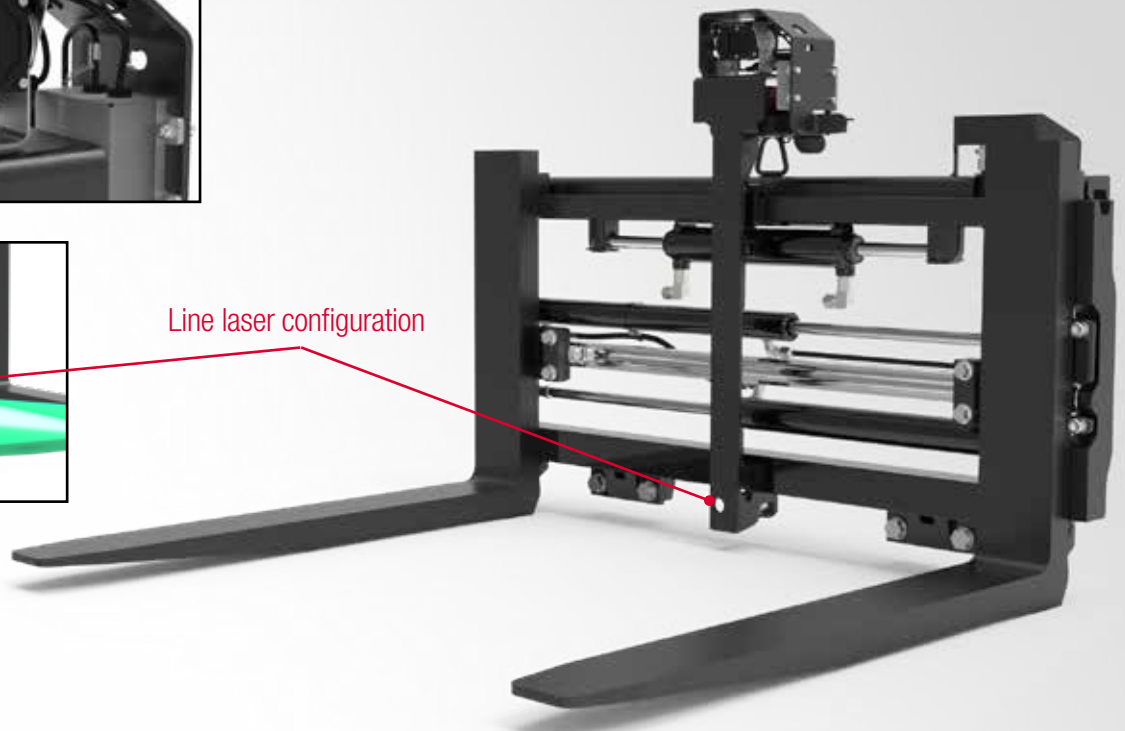

DESIGNED FOR ALL FORKLIFT TRUCKS

CENTERED VISION IN FRONT OF THE FORKLIFT

Easy-FORK Vision Systems significantly increase safety in the storage areas

The high quality front mounted camera is a great help to forklift truck driver during loading and unloading operations, particularly when moving pallets at high levels on shelves.

The front camera is positioned on top of a central support allowing both camera and laser installation.

Amongst the Easy-FORK Vision System solutions, the front camera is particularly suitable for side shifting and fork positioning heavy-duty applications.

This robust camera has a waterproof IP69K protection, is 10G highly shock resistant, and is equipped with demisting system which makes it suitable for cold room applications. The camera is positioned in a stainless steel support, together with the laser battery.

Thanks to the camera position, the driver can have a clear view on

both fork tips, in the majority of operating conditions, with central 120° viewing angle, while maintaining the correct ergonomic position on the seat.

The color camera is equipped with 6 IR leds to enable a perfect vision even in low light environments. Images are displayed on a 7 inch. monitor installed inside the driver cabin which takes power from the truck battery. The connection between camera and monitor can be wireless or through a reinforced cable and cable-reel.

The well protected laser projects a linear blade with 90-degree angle which is aligned with the fork tips and guarantees the correct reference when loading a pallet. Laser is Radiation Class 1 category according to DIN EN 60825-1, which is safe even for long term intentional view.

Technical features



Camera:

- Waterproof IP69K
- Vibration 10G & Shock 100G
- Operating temperature
-20°C to +70°C / -4°F to +158 F.
- Dimensions: L 70 x H 44 x P 57 mm
(without brackets)
- Weight: 310g (without brackets)



Monitor:

- High-resolution 7" TFT LCD screen
- 16:9 display
- Supplied with metallic RAM
- 5 language display selection
- Operating temperature:
- 30°C to +70°C
22°F to +158°F



Line Laser:

- Laser Class 1
- Line laser, colour green, 90°
- Operating temperature:
-10°C to 60° / 14°F to 140°F
- Beam shape: line

CAMERA VIEWING ANGLE

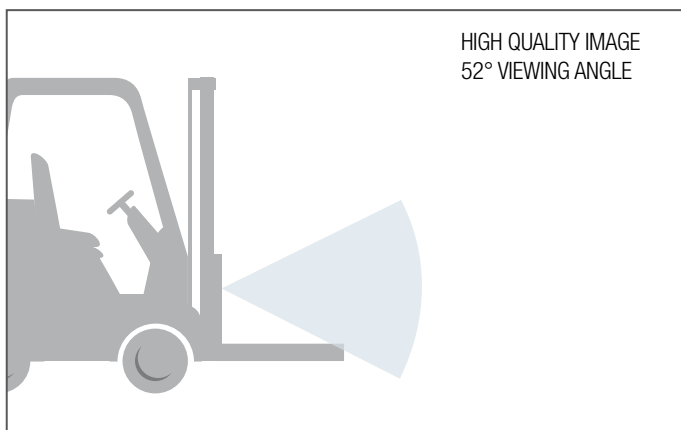

FRONT CAMERA VISIBILITY

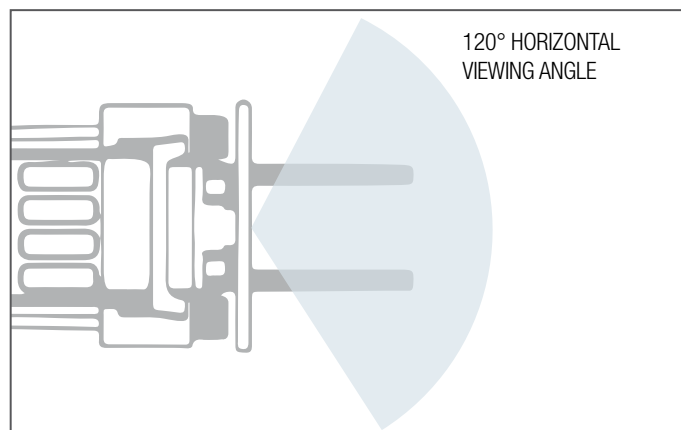

CONNECTION SYSTEM: WI-FI

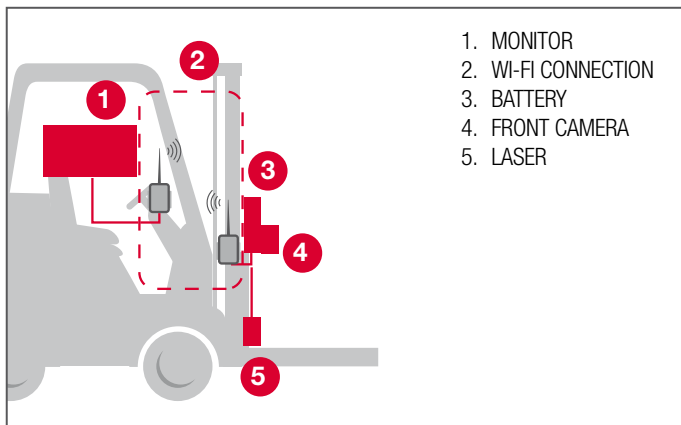

Options:

- Laser and camera can be requested separately
- Cable reel for hard wired application (wireless system as standard)
- Different cable lengths, on request.
- Digital video recorder with signal splitter.

The Easy-Fork Vision Systems range includes the Side fork camera, the Tip fork camera, and a solution to be installed on the fork carriage including Front camera and laser.